

PART Pièce	QTY. Qté.	ITEM Article
#1	2	TUBE 580 mm x 50 mm
#2	2	TUBE 450 mm x 50 mm
#3	2	TUBE 350 mm x 50 mm
#4	2	TUBE 222 mm x 50 mm
#5	8	TUBE 50 mm x 50 mm
#6	1	TUBE 40 mm x 40 mm
#7	4	TUBE 110 mm x 32 mm
#8	1	PRINTER SHELF tablette pour l'imprimante

PART Pièce	QTY. Qté.	ITEM Article
#9	1	TOP PANEL panneau supérieur
#10	1	HORIZONTAL SHELF tablette horizontale
#11	1	SLIDING SHELF tablette coulissante
#12	1	CPU SHELF tablette inférieure pour boîte à tour
#13	1	MIDDLE SHELF étagère centrale
#14	1	BOTTOM FIXED SHELF tablette inférieure fixe
#15	2	SLIDE glissière
#16	2	SLIDE SUPPORT support de glissière

Dear Customer,

DO NOT RETURN THIS PRODUCT TO YOUR RETAILER.

If you experience any problems during assembly, please contact Star customer service at **1-800-311-5611**. Or email to help@starquality.ca

Important:

All parts should be identified and matched up against the parts list. It is advisable to assemble on carpet to avoid scratches.

Cleaning Instructions:

Use a soft cloth with mild cleaning solution. Never use anything abrasive or any harsh chemicals.

TOOLS REQUIRED
Outils nécessaires



And



(PROVIDED)
(Inclus)



TWO PEOPLE REQUIRED
Deux personnes requises

Cher Client,

NE PAS RETOURNER CE PRODUIT À VOTRE DÉTAILLANT.









Si vous avez des problèmes lors de l'assemblage, s'il vous plaît veuillez contacter le service à la clientèle Star au **1-800-311-5611**. Ou par courrier électronique à help@starquality.ca

Important:

Vous devez pouvoir identifier toutes les pièces et les assortir à la liste des pièces. Il est conseillé de faire le montage sur un tapis pour éviter les éraflures.

Instructions de nettoyage:

Utilisez un chiffon doux avec un détergent doux. N'utilisez jamais d'abrasif ni de produits chimiques corrosifs.

PART pièce	QTY. Qté	ITEM Article		PART pièce	QTY. Qté	ITEM Article	
A	12	40X10 mm		F	4	BIG LEVELLER grande patte de mise à niveau	
B	6	20X10 mm		G	1	SMALL LEVELLER petite patte de mise à niveau	
C	1	20X8 mm		H	4	SCREW FOR SLIDE RUNNER vis pour coulisse	
D	4	130X8 mm		I	2	WASHER & NUT rondelle et écrou	
E	4	SMALL WASHER & NUT petite rondelle et écrou					

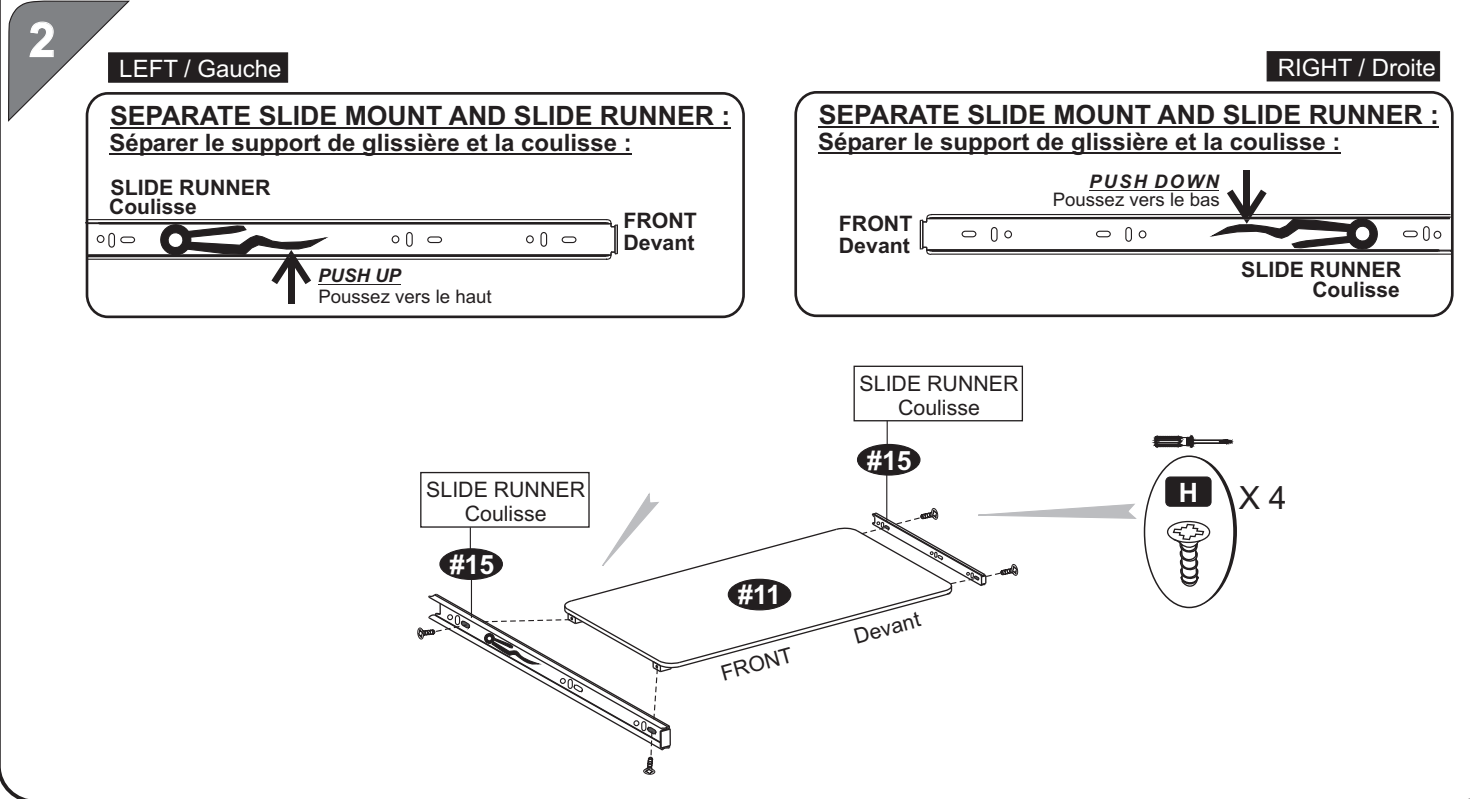
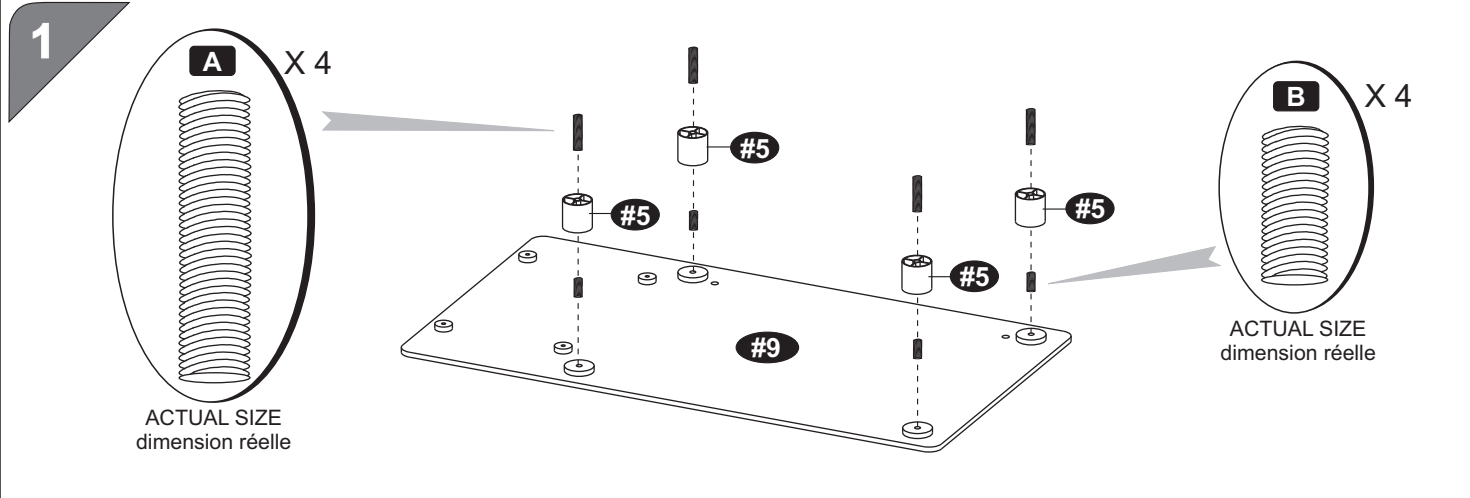

3

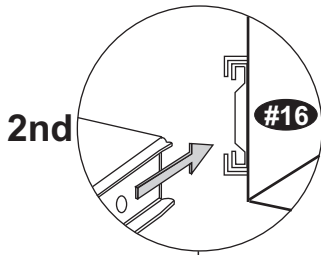

2nd

- ALIGN BOTH SIDES OF SLIDE RUNNERS TO SLIDE MOUNTS' OPENINGS, THEN SLIDE IN SLIDING SHELF ALL THE WAY IN.
- APPLY SMALL FORCE TO INSERT COMPLETELY IF NEEDED.
- Aligner les deux côtés des coulisses sur les ouvertures des supports de glissières, ensuite glisser la tablette coulissante vers l'intérieur.
- Enfoncer fermement.

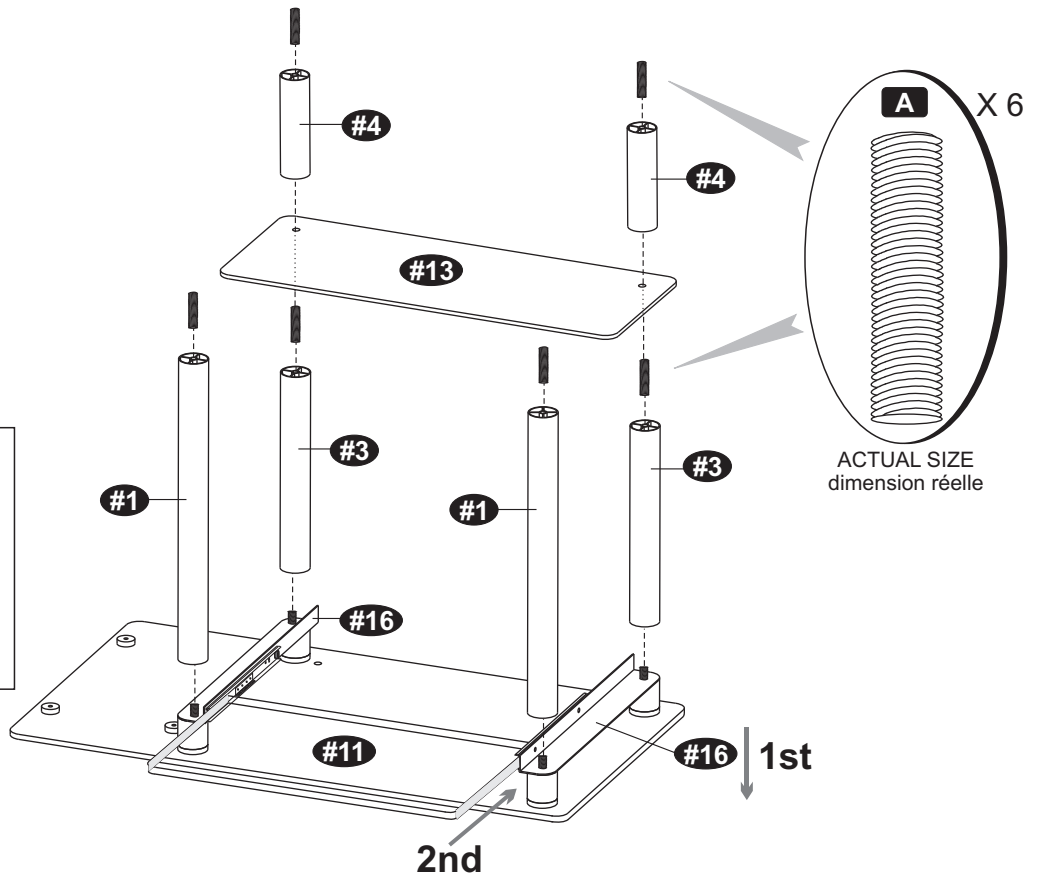

4

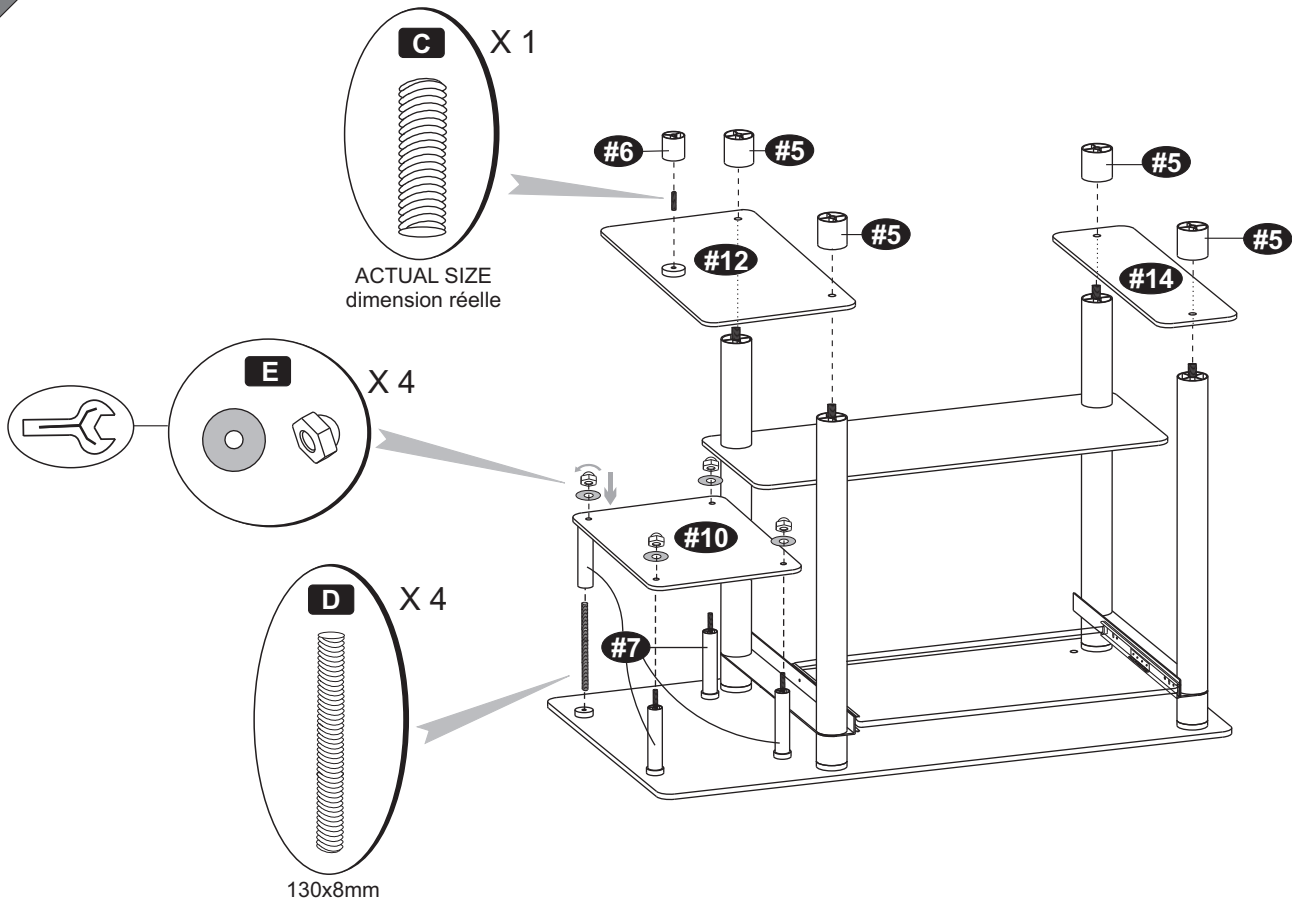

5

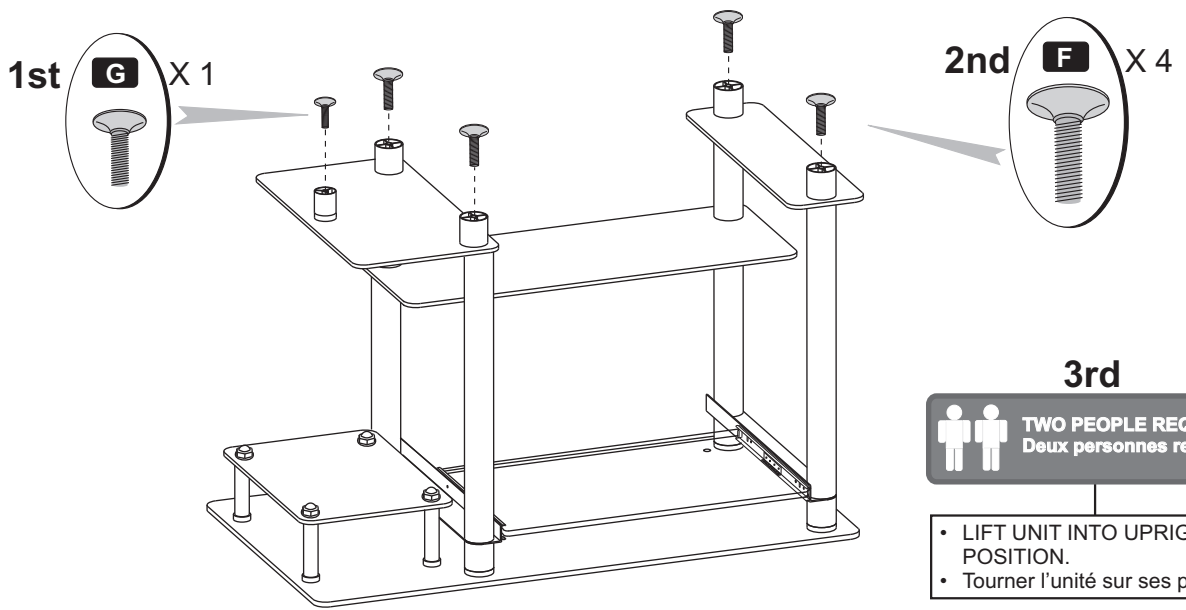

6

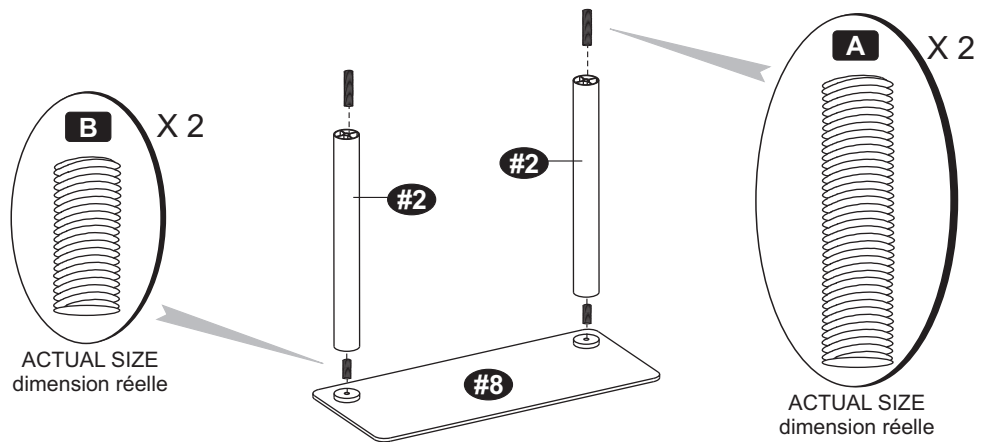

7

