

PART pièce	QTY. Qté	ITEM Article		PART pièce	QTY. Qté	ITEM Article					
TP	1	TOP PANEL panneau supérieur		A	10	CONNECTOR HOUSING logement de raccordement					
BK	1	BACK PANEL panneau arrière		B	10	SCREWBOLT boulon fileté					
SDR	1	RIGHT SIDE PANEL panneau latéral droit		C	10	DOWEL Cheville de bois					
SDL	1	LEFT SIDE PANEL panneau latéral gauche		D	14	PLASTIC CAP cache vis					
TOOLS REQUIRED Outils nécessaires				TWO PEOPLE REQUIRED Deux personnes requises				E	4	LEVELLER patte de mise à niveau	

Dear Customer,

Do not return this product to your retailer. If you experience any problems during assembly, please contact Star customer service at **1-800-311-5611**. Or email to **customerservice@starquality.ca** It is advisable to assemble on carpet to avoid scratches.

Cher Client,

Ne pas retourner ce produit à votre détaillant. Si vous avez des problèmes lors de l'assemblage, s'il vous plaît veuillez contacter le service à la clientèle Star au **1-800-311-5611**. Ou par courrier électronique à **customerservice@starquality.ca** Il est conseillé de faire le montage sur un tapis pour éviter les éraflures.

1

1st

A



X10

- ARROW ON CONNECTOR HOUSINGS SHOULD FACE CLOSEST EDGE.
- La flèche doit être face au bord le plus proche.

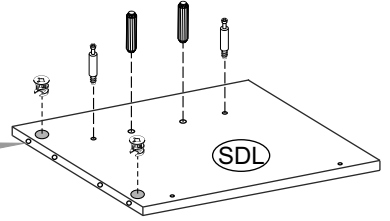
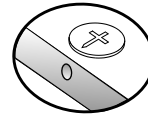
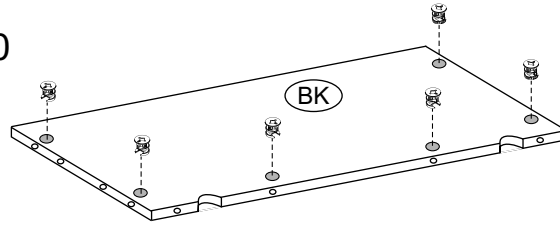
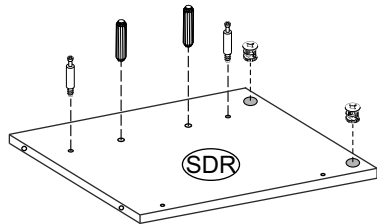

2nd

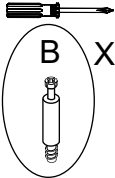

X 10

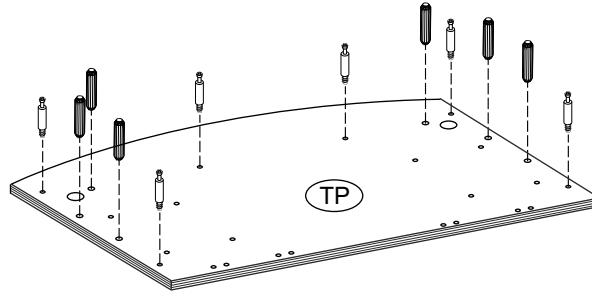

3rd

C

X 10

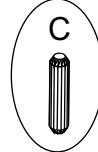

2

2nd & 4th

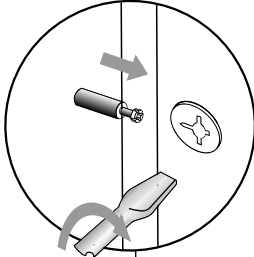

3rd

1st

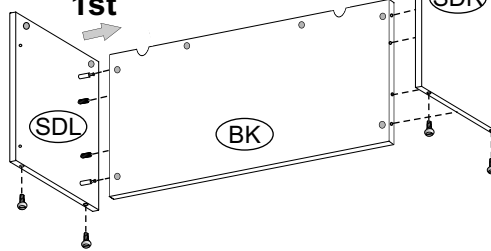

5th

E

X4

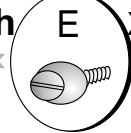

- TIGHTEN ALL CONNECTOR HOUSINGS BY TURNING CLOCKWISE WITH SCREWDRIVER 1/2 TURN OR UNTIL IT STOPS.
- Ressersez les logements de raccordement en tournant dans le sens des aiguilles d'une montre avec un tournevis d'un demi tour ou jusqu'à ce que le logement de raccordement s'arrête.

3



1st

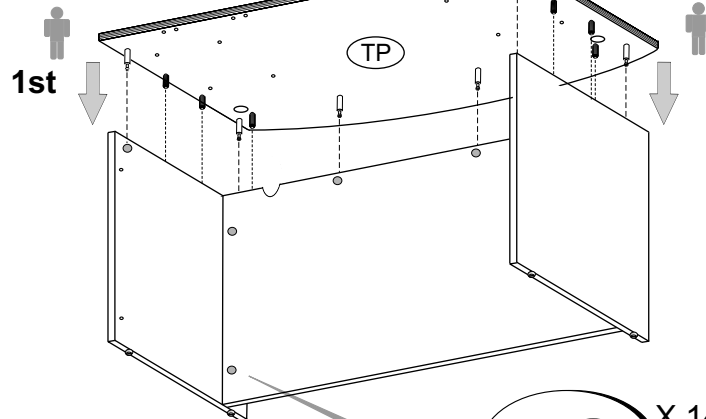

2nd

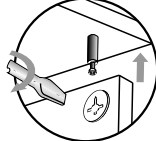

3rd

D

X 14

